

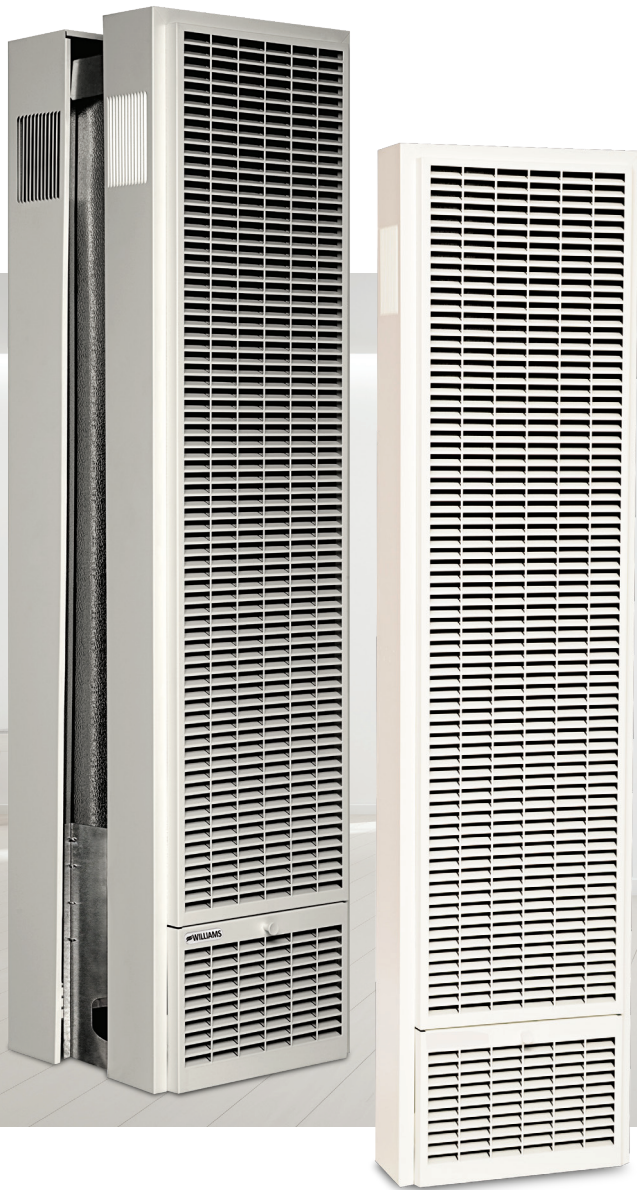

MONTEREY PLUS™ HOME FURNACES



DUAL-WALL TOP-VENT
50,000 BTU/hr.

25,000 - 35,000
BTU/hr.

Monterey Plus Home Furnaces offer traditional home comfort with lower heating costs, convenience and high efficiency. Easily recessed or surface-mounted options are great in homes, schools, cabins, apartments, offices and shops.

Heating rooms individually allows comfort in areas being used while saving fuel costs in unused areas.

For additional money-saving efficiency, install one of our optional blowers.

FEATURES

- No electricity required
- “Matchless” pilot igniter
- Easy installation
- Patented side-relief opening draft hood design reduces flue gas temperature to minimize normal heat loss
- Natural or propane models (*conversion kits available*)
- Automatic temperature and safety controls
- Resettable vent-limit safety switch

Williams’ dual-wall model, with patented energy-maximizing side-relief draft hood openings, will heat two or more rooms quickly and economically. Conveniently installs in the wall to heat two adjacent rooms (*25,000 BTU/hr. on each side*).





MONTEREY PLUS HOME FURNACES

MODEL NUMBER		BTU/hr. INPUT	BTU/hr. OUTPUT	EFFICIENCY PERCENT		DIMENSIONS (INCHES)			THERMOSTAT	SHIPPING WEIGHT (LBS.)
NATURAL	PROPANE			THERMAL	AFUE	WIDTH	DEPTH	HEIGHT		
SINGLE-SIDED FURNACES CONVERSION KITS AVAILABLE										
2509822	2509821	25,000	19,200	77	71	16	6	65 ¾	MILLIVOLT	83
3509822	3509821	35,000	25,000	71	70	16	6	65 ¾	MILLIVOLT	83
DOUBLE-SIDED FURNACES CONVERSION KITS AVAILABLE										
5009822	5009821	50,000	38,000	78	70	16	6 EACH SIDE	65 ¾	MILLIVOLT	137

Elevation rating from sea level to 2,000'

Consult Owner's Manual for installation of product at elevations over 2000'

1/2" Gas Connection

FEATURES

"MATCHLESS" PILOT IGNITER

All models include a "matchless" pilot igniter that assures convenient pilot lighting without matches.

CONTEMPORARY FINISH

Soft-white, powder-coat, heat-resistant finish to compliment any decor.

INTERIOR FURNACE CLEARANCES

- 4" from an intersecting wall.
- 16" from the top of the appliance to the ceiling or other obstructions.
- 48" from the furnace front to draperies, furniture or other obstructions, or other combustibles.
- 2 ½" from finished floor.

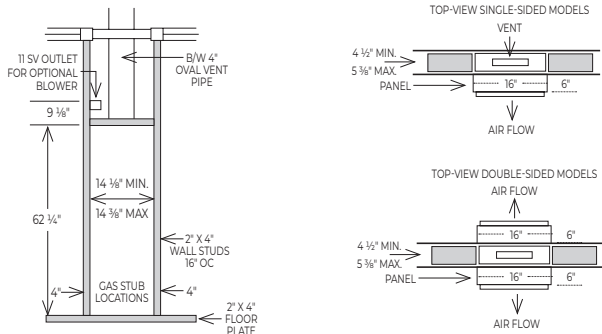

IMPORTANT

- Read owner's manual before using/installing.
- Photographs are representative only.
- Check local codes and ordinances for permitted uses.
- Consult installation manual for clearances prior to installation.
- We reserve the right to amend product specifications without notice.
- Installation and servicing recommended by a qualified service person.
- Please read the warranty for any limitations of disclaimers. Combustion chamber carries a 10-year limited warranty. All other parts carry a one-year limited warranty.
- Venting must comply with the "Venting and Chimney Requirements" section of the instruction manual.
- Massachusetts Approval GI-0816-23.



WARNING: This product can expose you to chemicals including epichlorohydrin which is known to the State of California to cause cancer and birth defects and/or other reproductive harm. For more information go to www.p65warnings.ca.gov

ACCESSORIES

THERMOSTAT SOLD SEPARATELY part number P322016

BLOWER

Attaches to top of the Monterey furnaces with ON/OFF switch or automatic operation. Improves circulation of warm air and reduces temperature differences in the room. Optional deluxe blower for increased airflow. Two blowers may be used on 50,000 BTU/hr. units.

- Model 2901** - 100 CFM, shipping weight 9 lbs.
- Model 2907** - 125 CFM, shipping weight 9 lbs.



REAR-OUTLET REGISTER

Chain operated damper with register flush on rear wall, adjusts amount of heat delivered through rear register. Motorized rear outlet register for increased airflow also available.

- Model 6901** - Standard model, shipping weight 4 lbs.
- Model 6920** - Motorized model for surface mounted installation. Shipping weight 6919 and 6920, 10 lbs.



CONVERSION KITS

Natural gas to LP or LP to Natural gas selections available.

OVAL-VENT STARTER KIT

Contains hold down plate, oval-to-round adapter, spacer plates and two pieces of 2-foot lengths of oval pipe.

- Model 9929** - USA
- Model 9930** - Canada
- Shipping weight 9 lbs.



REPLACEMENT FACE PANEL

Soft white powder coat face panel
Model 4915 - shipping weight 30 lbs.



VENT ADAPTER

Surface-mounted furnace installations only.
Model 9902 - Without optional blower installed.



FREE-STANDING KIT

Allows single sided furnaces to be surface mounted instead of recessed Ideal for remodeling in existing masonry construction or when studs are substandard. (furnace and face panel not included.)

- Model 4901** - Shipping weight 23 lbs.